



Fitting Instructions

SY8A
TOWBAR
For **SSANGYONG KYRON**
2006-

MATERIALS

A	1	Cross Bar
B	2	Lower Spreader Plate
C	2	Upper Spreader Plate
D	2	Bush Assembly
E	1	Left side Arm
F	1	Right side Arm
G	4	M14x140x2.00mm Bolt, 4 Nyloc Nuts, 40mm O.D Flat Washers Qty 8.
H	6	M14 x 50x2.00mm side Bolts, 4 Nuts, 4 Lock Washers, 30mm O.D Flat Washers Qty10
I	1	Left hand side Bumper support
J	1	Right Hand side Bumper Support
K	2	M8 X 25mmx1.25mm Bolts, 4x 20mm Washers, 2 nuts
L	2	M16x50mm, 2 Lock Washers, 2Nuts, 2 Bolt Caps.
ZEP	1	Electrical Plate (ZEP35) fit as shown

FITTING

1. Firstly remove the rear light clusters (**Open the tail gate and unscrew the x2 mounting screws either side of the clusters. Disconnect the cable and carefully pull clusters rearward.**)
2. Remove the rear bumper (**Unscrew the x2 mounting bolts from the black mounting brackets, unscrew the x2 mounting screw in the top edge of the bumper, remove the x5 plastic scrivenets in the top face of the bumper, remove the x2 mounting bolts from beneath the bumper and x7 screws in each of the wheel arches.** Ensure reversing sensor cables are disconnected.
3. Remove the foam packing and the rear crash member (**x4 Bolts**) to open the ends of the chassis rails.
4. Slide Bush Assembly (**D**) into each of the open chassis rails, aligning with the existing vertical holes.
5. Loosely attach side arms (E) & (F) to the underside of the chassis rail using the 2 most rear fasteners for support (G).
6. Whilst keeping the two **rear** most bolts loose (G), slide on to the top face of the chassis rails the Lower Spreader Plate (**B**) and Upper Spreader Plate (**C**), ensuring the washer sits above all. Use the diagram below as reference.
7. Align the Spreader Plates (**B & C**) and thread the forward fasteners (**G**) vertically sandwiching all components.
8. Loosely attach the Cross Bar (A) to the side arms (E) & (F) using Bolts (H). Note: Fitment will be eased if two people are used during this assembly. **Important:** Brackets (**J & I**) must be fitted before **rear most bolt H** is tightened.
9. Fully tighten fasteners (**G&H**) to their recommended torque setting once satisfied with tow bar positioning around the spare wheel carrier. (**Note:** Vehicles fitted with Reverse sensors, cable tie the loom around the bar ensuring significant clearance away from the exhaust.)
10. Cut Bumper as per diagram. (Tip: offer the bumper to the rear of the vehicle as a guide for cutting position.)
11. Remove the crash beam from the bumper and reattach the rear bumper and light clusters in reverse order to removal. (**Note:** Please protect the rear face of the bumper from scratches when reattaching)
12. Using Brackets (**J & I**) attach the bumper lug to the brackets using the M8 bolts and washers (**K**)
13. Attach the ZEP electrical plate followed by the Z11 tow ball using bolts (**L**). Attach Bolt Caps
14. Ensure all fasteners have been tightened to their recommended torque setting.

Note: This towbar must be used with either a Witter Tow ball (part number **Z11**) or Class A50-1 or A50-X tow ball dimensionally Conforming to A50-1 with a 'D' and 'S' value greater than or equal to that of the tow bar.

Please refer to the vehicle specification for the trailer weight and nose limits, which **must be observed**.

Recommended torque settings: M8 - 27Nm, M10 - 53 Nm, M12 - 95 Nm, M14 - 150 Nm, M16 - 214 Nm

SY8A Illustration

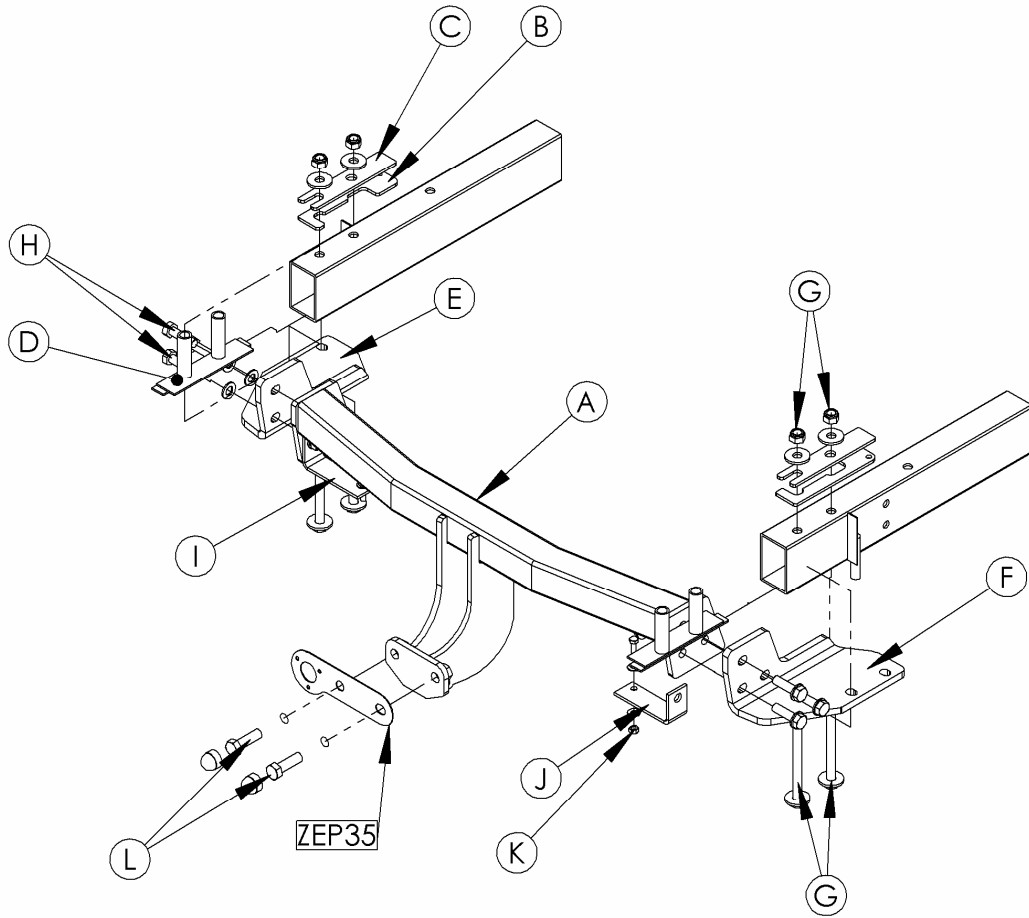

Bumper Cut

